

# Jet Scrubber Type II

## General

Jet scrubbers are unique among gas scrubbers. They work on the injection principle and are the only scrubbers which produce an increase rather than a loss in pressure in the gas flow. Thus, when using a jet scrubber as a gas scrubber, there is generally no requirement for a mechanical ventilator for extracting and conveying the gases.

## Design

Jet scrubber type II represents a constructional variation to the traditional jet scrubber. The scrubber tube is integrated in the separator tank and has an elliptical cross section. The size of the cross section can be freely selected. The elliptical shape is particularly advantageous when the nominal width of the unit is large because, in contrast to the circular cross section, the depth to which the gas penetrates through the liquid flow is considerably reduced. The height of the chamber



Fig. 1 Jet Scrubber Type II DN 600 from polypropylene (PP)

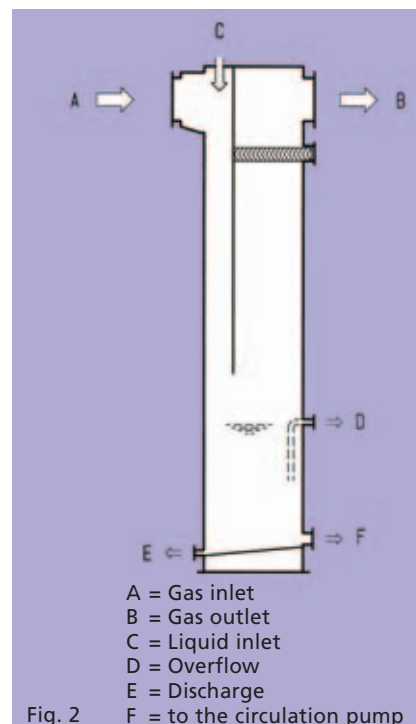

Fig. 2 F = to the circulation pump

available to the rising gas in the separator section not only provides optimal inward flowing conditions for the installed droplet separator but can also be used in various ways to improve the separation performance, e.g. by installing a counter facility or a packed unit.

Therefore, jet scrubber type II, combines in one unit the advantages of the jet scrubber with the possibilities of the counter-flow scrubber. The compact construction of jet scrubber type II offers considerable advantages, in particular in the case of larger equipment with high volume flows, on account of its low construction and the small space requirement.

## Materials

Plastics :  
thermoplastic with or without GRP reinforcement as, for example, PP, PE, PVDF

Steel:  
with or without corrosion protection, stainless steel and special materials.

## Jet Scrubber Type II Standard version

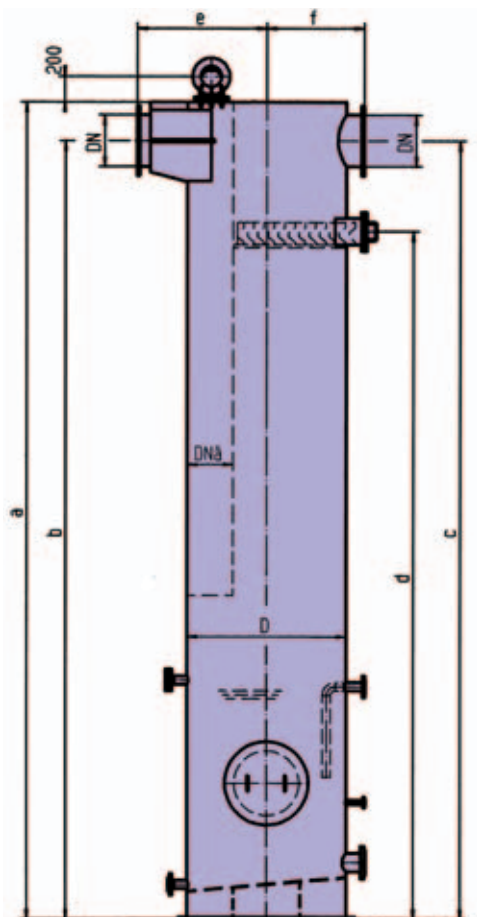

Fig. 3

### Areas of application

- o Gas conveyance
- o Gas saturation and cooling
- o Condensation
- o Separation of harmful substances (absorption)
- o Solids separation (de-dusting)

### Advantages

- o Wide area of application
- o Auto-suction
- o No pressure loss
- o Large load, efficient on partial load
- o Can be flexibly combined and extended
- o Available in nearly all materials
- o Resistant to fouling
- o High level of reliability
- o Little maintenance
- o Low construction, small space requirement
- o Large equipment dimensions possible

### Suction flow, main connections and overall dimensions

Connection DN	Equivalent wash tube diameter DNä	Suction flow range in m <sup>3</sup> /h	Main dimensions in mm					
			D	a	b = c	d	e	f
300	400	2700 - 4500	1000	4600	4350	3700	900	700
400	500	4000 - 7000	1200	5000	4700	4000	1000	800
500	600	7000 - 10000	1400	5500	5150	4400	1150	900
600	700	10000 - 14000	1600	5900	5500	4700	1300	1000
700	800	14000 - 18000	1800	6400	5950	5000	1400	1100
800	900	16000 - 23000	2000	6800	6300	5400	1600	1200
900	1000	20000 - 28000	2200	7300	6700	5700	1700	1300
1000	1100	26000 - 35000	2300	7800	7150	6100	1800	1350
1100	1200	30000 - 40000	2400	8300	7600	6500	1900	1400
1200	1300	38000 - 50000	2500	8800	8450	6900	2000	1450

Larger plants on enquiry

Dimensions not binding

For all inquiries please use our questionnaire .